

User & Installation Manual

LINK Modular



Introduction

LINK stands as the newest member of the linear interior family, introducing a versatile array of options to diverse lighting needs. Notably, it boasts a low Unified Glare Rating (UGR), guaranteeing a glare rating of less than 19. This feature positions LINK as a choice for environments where reducing glare is paramount, with a particular emphasis on enhancing the overall lighting quality within workplace settings. The incorporation of this aligns LINK with the highest standards, making it a compelling solution for those seeking an optimal blend of functionality and visual comfort.

- Link series is available for surface, pendant and recessed application
- It is also offered in superior models with the option of customizing the output of the luminaire every 28cm.
- Directional and diffused options are offered with Samsung LED: L90/B10 >50.000h
- Spot options are offered with Cree LED: L90/B10 >50.000h, 3SDCM Indoor use: IP40

At ELECTRON we value each and every customer, and we want to thank you for your purchase of LINK. We believe that this manual will serve as a useful guide and resource for you, and we look forward to hearing your feedback.

Please note that before using this equipment it is mandatory, for safety reasons and for the proper use of LINK, to read carefully this user manual.

ELECTRON SA



Reproduction of all or part of this user manual, in any form, is not allowed without prior written authorization from Electron SA.

Electron SA reserves the right to make any changes in this user manual without any prior notice.

Table of Contents

Introduction	2
General notes and precautions	4
Before first use.	4
Installation.	4
Mechanical.....	4
Electrical.	4
General.....	5
Physical Information.....	6
Unpacking the Fixture.....	7
Tools and Materials Required	7
Tools.....	7
Installation Steps	7
Preparation	7
Measuring and Marking	8
Cutting the Aluminum Profile.....	8
Drilling Holes in the Aluminum Profile.....	8
Testing and Final Adjustments	8
Guidelines	9
Directional Models.	9
Aluminum Profile Preparation	9
Electrical Connection.....	10
Diffused Models.	11
Aluminum Profile Preparation	11
Spot Models.....	13
Aluminum Profile Preparation	13
Electrical Connection.....	13
Mounting the Fixture	14
Surface Mounting.	14
Pendant Mounting.	14
Wire Connection:	14
Recessed Installation.	15
Cables and power connector's description.	16
Technical specifications.	16
Maintenance and Troubleshooting.....	Error! Bookmark not defined.

General notes and precautions.

Before first use.

- Make sure to read thoroughly all the instructions before using the LINK.
- In case that you do not understand any of the instructions or have any doubt for the installation or operation of the LINK, please consult your supplier.
- The installation of LINK must be done by a specialized technician.

Installation.

- LINK must not be installed, in any case, on flammable areas.
- Do not install LINK near any kind of heating source.
- Do not cover the fixtures with thermal insulation material.
- The user must ensure that the false ceiling can support the weight of the installed fixtures.
- **Make sure that the power supply is turned off during the installation procedure.**



Mechanical.

- Make sure that LINK is properly installed, safely mounted and connected.
- When needed, the replacement of the front mask and lenses must be done by using authentic spare parts only and from authorized technicians.

Electrical.







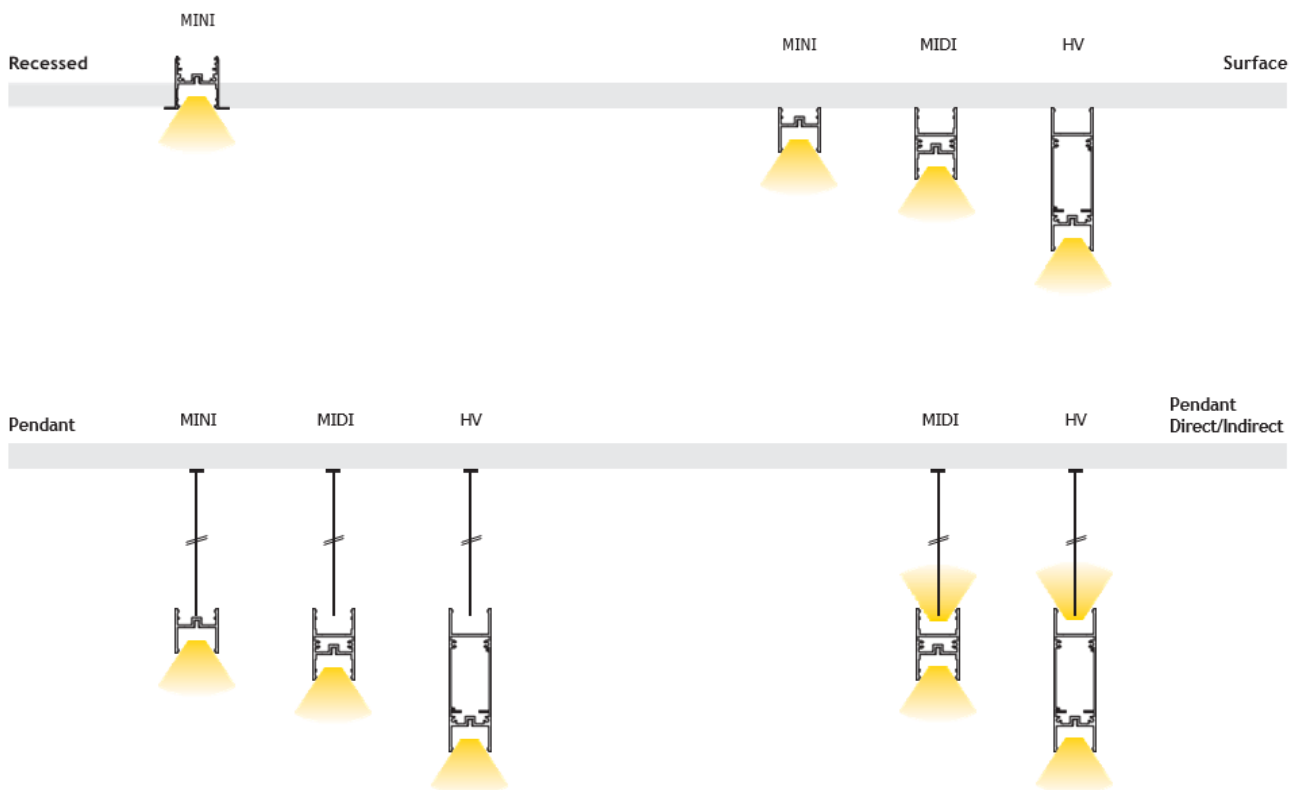



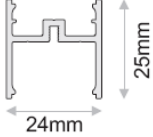



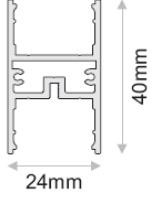

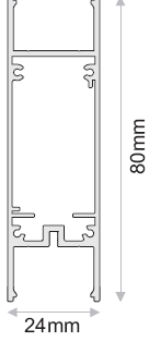
- The luminaire must be connected only by a qualified electrician.
- The supply input of multichannel LINK models (RGBW, Tunable white) is common anode, and the appropriate power supply and controller should be used.
- Dimming can be accomplished by PWM (up to 4kHz) on power supply input.
- LINK are class III devices.
- Disconnect the power supply for any service.

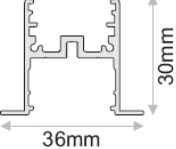
General.

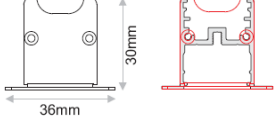
- Do not look directly to the LINK'S light source when it's turned on.
 - Do not try to fix any damage or malfunction, by opening the LINK. This must be done by an experienced and specialized technician of your supplier.
 - LINK should be cleaned only with a soft cloth and water.
 - The manufacturer is not responsible for any injury or damage that will occur from the improper installation or use of the product.
 - The safety of this fixture is guaranteed only if you comply with the following instructions.
 - Make sure that all the local laws and regulations are followed during the installation procedure.
-
- Remember to conserve these instructions in a safe place.
 - At the end of its lifetime LINK must be delivered in a special waste collection center. The improper disposal can cause damages for the environment and poses dangers for the human health.

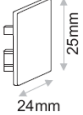

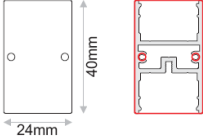
Physical Information

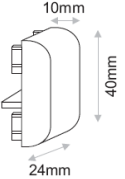
Image	Code	Description	Weight	Material	Moment of Inertia Ix (cm4)	Profile Area (cm2)	Design-Detail
	PRF.180	LINK MINI alum.prof.	0.3 kg/m	EN AW 6060 T66	0.39	1.05	
	PRF.181	LINK BASE/BLANK alum.prof.	0,1 kg/m		0.004	0.33	
	PRF.182	LINK MIDI alum.prof.	0,5 kg/m		1.50	1.87	
	PRF.183	LINK HV alum.prof.	0,8 kg/m		2.96	2.97	
	PRF.184	LINK MINI RC alum.prof.	0,4 kg/m		0.87	1.45	
	CAP.166	Anodized CAPW166 White CAPB166 Black	LINK MINI RC Cap				
	CAPW167	White CAPB167 Black	LINK MINI Cap				
	CAP.168	Anodized CAPW168 White CAPB168 Black	LINK MIDI Cap				
	CAPW170	White CAPB170 Black	LINK MIDI Curved Edge Cap				



CAP.169 Anodized
CAPW169 White
CAPB169 Black

LINK HV Cap

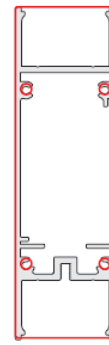
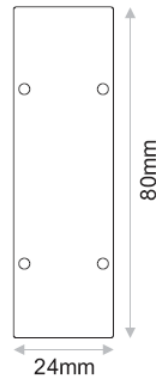

CAPW171 White
CAPB171 Black

LINK HV Curved
Edge Cap

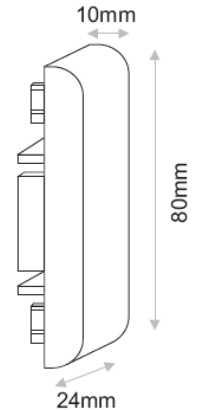

Unpacking the Fixture

- Carefully unpack the light fixture from the packaging.
- Check all components against the parts list to ensure nothing is missing.
- Inspect the products for any damage that may have occurred during shipping.

Tools and Materials Required

Tools

- Measuring tape.
- Marker or pencil.
- Metal saw or miter saw with an aluminum-cutting blade.
- Drill with metal drill bits.
- Screwdriver set.
- Soldering iron.
- Level.
- Safety glasses.
- Gloves.
- Clamps (optional).

Installation Steps

Preparation

- Unpack all components and ensure you have all the necessary parts.
- Identify the location where the modules will be installed. Make sure the area is clear of obstructions and that there is access to a power source.
- Clean the aluminum profile and the installation area to remove any dust or debris.

Measuring and Marking

- Measure the length required for your installation.
- Use a marker or pencil to mark the cut lines on the aluminum profile. Be precise to ensure a clean and accurate cut.
- Mark the positions where the holes will be drilled for mounting base and electrical connections.

Cutting the Aluminum Profile

- Secure the aluminum profile on a stable work surface using clamps (if available).
- Using a metal saw or miter saw, carefully cut the aluminum profile along the marked lines. Ensure you cut straight to maintain the integrity of the profile.
- Smooth any rough edges with a metal file or sandpaper to avoid injury or damage during assembly.

Drilling Holes in the Aluminum Profile

- Mark the positions for the holes on the aluminum profile according to your measurements.
- Attach a metal drill bit to your drill and carefully drill holes at the marked positions. Ensure the holes are clean and free of burrs.
- Double-check that the holes align with the mounting brackets and electrical connections.

Testing and Final Adjustments

- Turn on the power supply and test the modules to ensure they function correctly.
- If any LED modules do not light up, double-check the wiring connections.
- Adjust the module positioning if necessary to ensure an even distribution of light.



Guidelines

Directional Models.

*The maximum length that can be achieved with the Directional modules is 224cm (8modules). If it is necessary, dimensions greater than 224cm then two individual circuits must be made.

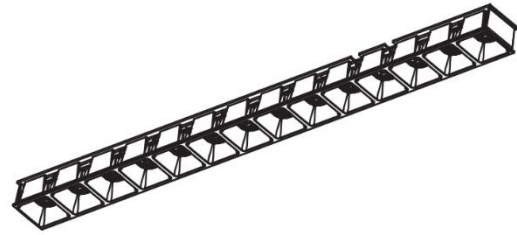

for

Aluminum Profile Preparation

1. Cut the **PRF.180/PRF.182/PRF.183/PRF.184** to the desired dimension (multiple of 28cm).
2. At the end of the profile perform a cut 15x5mm with a 5mm end mill to pass the cables.

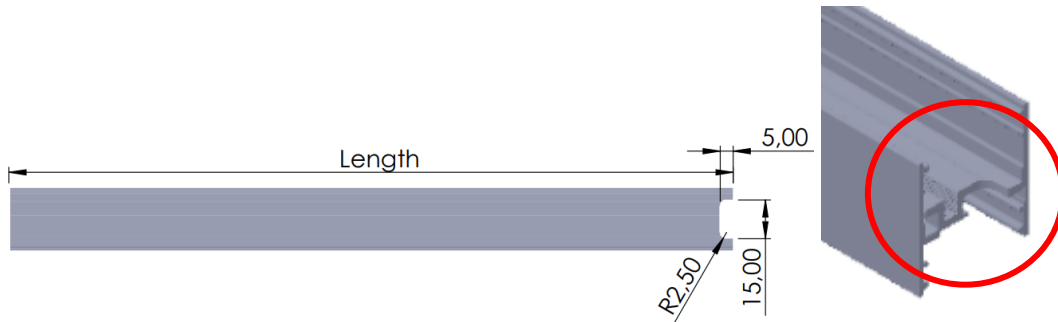

3. **For Surface Installation** cut the **PRF.181** 140mm smaller than the main aluminum profile.
 - a. Drill the necessary mounting holes. Recommended screws: Countersunk Phillips DIN 7982 D:3.5~3.9mm. It is recommended to have mounting holes every 40 cm.

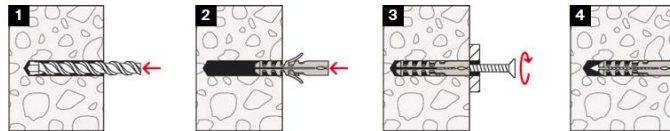

4. **For Pendant Installation** cut the **PRF.181** the same size with the main aluminum profile.
 - a. Drill two holes $\varnothing 4.50\text{mm}$. To mount the ceiling suspension (**ACC.191/ACC.233**)
 - b. Drill a hole $\varnothing 12\text{mm}$ for the cable gland **PRH.038**. It is recommended to place the gland near the suspension to guide the cable along with the safety wire using a cable restrain (**PRH.037**).

Electrical Connection.

1. Pass the cables through the holes and solder them on the first PCB Module (a).
2. At the end of each PCB make sure to place double side tape in order to insulate the connection (b).
3. Place the first LED PCB in the aluminum profile, then place the following PCB and solder them together as illustrated (c).
4. Once all the connections are made then the lens can be carefully place on the LED PCBs and secured in place with the provided screws (M3x6mm) (d).
5. Finally, the masks can be installed (e1), bear in mind that if the solder connection between the PCBs is not done correctly then the end of the masks must be slightly trimmed (e2).

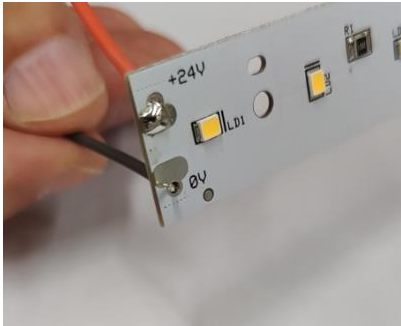

(a)



(b)

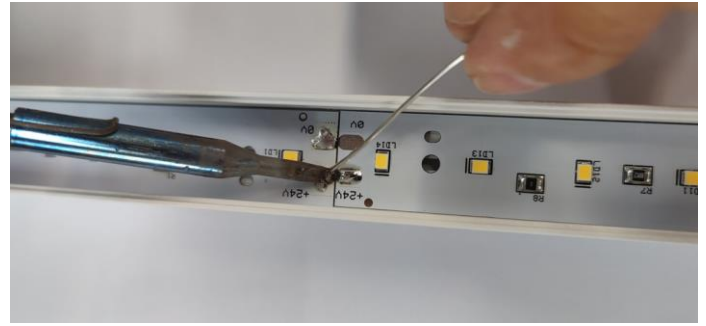

(c)



(d)

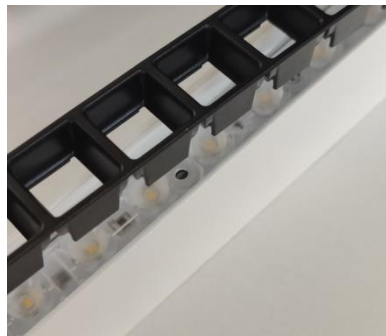

(e1)

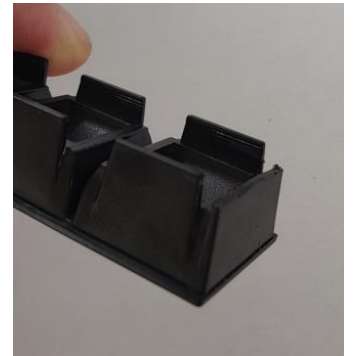

(e2)



Diffused Models.

*The maximum length that can be achieved on Diffused models with a single power supply is 4,97m (71sections of 70mm (TIV.540/541/542))



Aluminum Profile Preparation

1. Cut the **PRF.180/PRF.182/PRF.183/PRF.184** to the desired dimension (multiple of 28cm).
2. At the end of the profile perform a cut 15x5mm with a 5mm end mill to pass the cables.

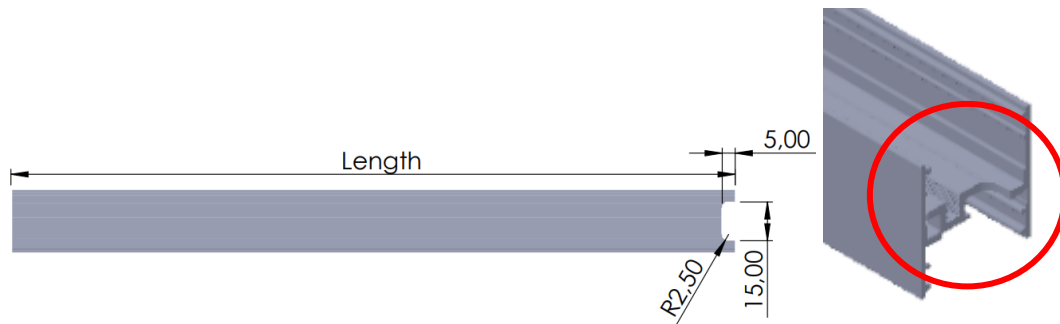

3. **For Surface Installation** cut the **PRF.181** 140mm smaller than the main aluminum profile.
 - a. Drill the necessary mounting holes. Recommended screws: Countersunk Phillips DIN 7982 D:3.5~3.9mm. It is recommended to have mounting holes every 40 cm.

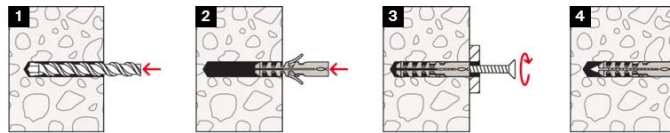

4. **For Pendant Installation** cut the PRF.181 the same size with the main aluminum profile.
 - a. Drill two holes $\varnothing 4.50\text{mm}$. To mount the ceiling suspension (ACC.191/ACC.233)
 - b. Drill a hole $\varnothing 12\text{mm}$ for the cable gland **PRH.038**. It is recommended to place the gland near the suspension to guide the cable along with the safety wire using a cable restrain (**PRH.037**).

Electrical Connection.

1. Cut the led strip at the desired length, only at the cutting marks (a).
2. Insert a heat-shrinkable tubing at the side of the led trip, where the cables will be soldered. Then, solder the cables on the led strip pads. (b)
3. Slide the heat-shrinkable tubing, to cover the soldered led strip pads. Then, heat it in order to shrunk and wrap the led strip (c).
4. Remove gradually the masking tape and stick the led strip on the Link profile (d).

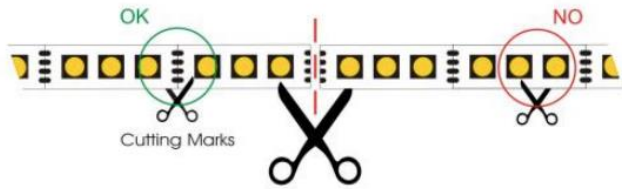

(a)

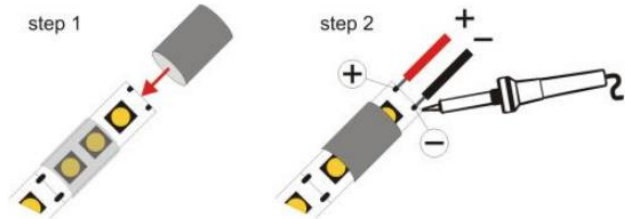

(b)

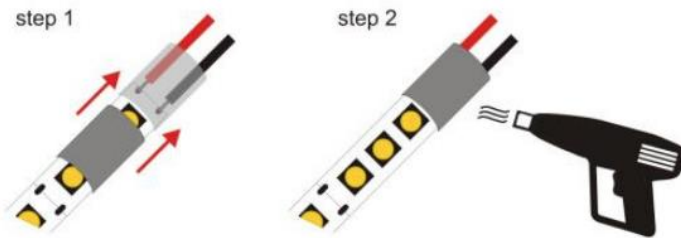

(c)

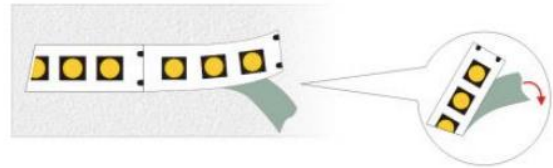

(d)

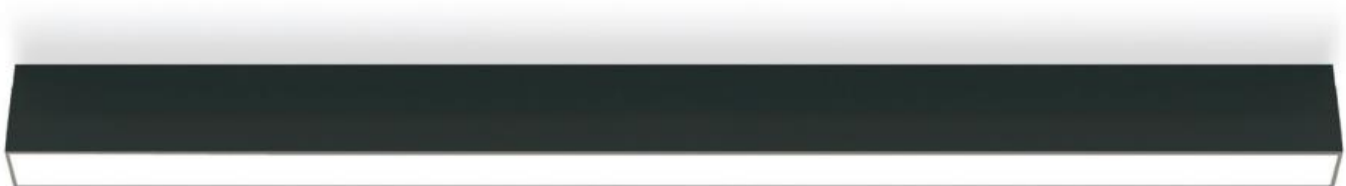
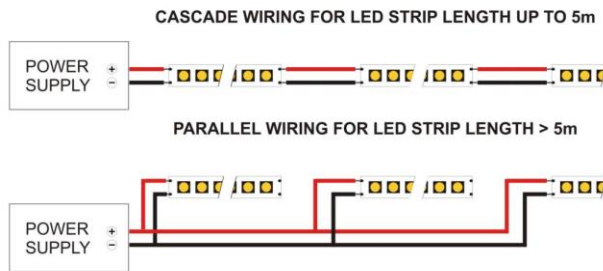

Spot Models.

Aluminum Profile Preparation

1. Cut the **PRF.180/PRF.182/PRF.183/PRF.184** to the desired dimension (multiple of 28cm).
2. At the end of the profile perform a cut 15x5mm with a 5mm end mill to pass the cables.
3. Every ~28cm drill a hole $\varnothing 8\text{mm}$ in order to pass the cables from the spot modules.

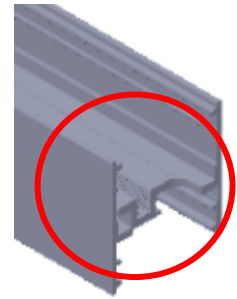
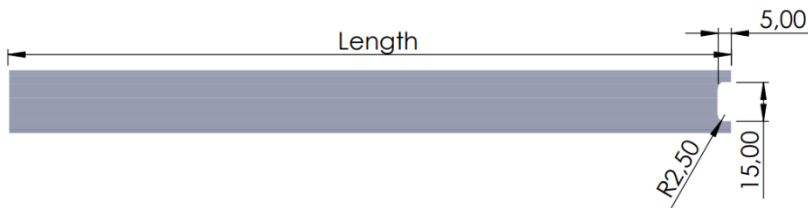
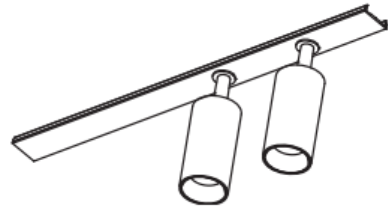

4. **For Surface Installation** cut the **PRF.181** 140mm smaller than the main aluminum profile.
 - a. Drill the necessary mounting holes. Recommended screws: Countersunk Phillips DIN 7982 D:3.5~3.9mm. It is recommended to have mounting holes every 40 cm.

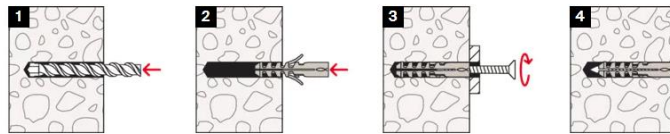

5. **For Pendant Installation** cut the **PRF.181** the same size with the main aluminum profile.
 - a. Drill two holes $\varnothing 4.50\text{mm}$. To mount the ceiling suspension (**ACC.191/ACC.233**)
 - b. Drill a hole $\varnothing 12\text{mm}$ for the cable gland **PRH.038**. It is recommended to place the gland near the suspension to guide the cable along with the safety wire using a cable restrain (**PRH.037**).

Electrical Connection.

1. Pass the cables through the holes and connect them to a power supply.

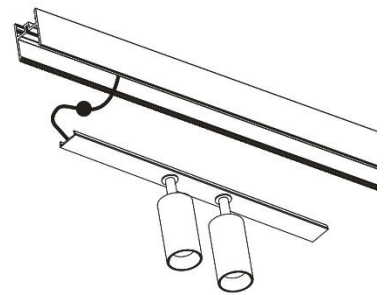

Mounting the Fixture

Prepare the mounting surface:

- Ensure the mounting surface is clean and capable of supporting the fixture's weight.
- Mark the drill points using the mounting base as a guide.
- Use the appropriate screws and wall anchors to secure the mounting base to the ceiling or wall.

Surface Mounting.

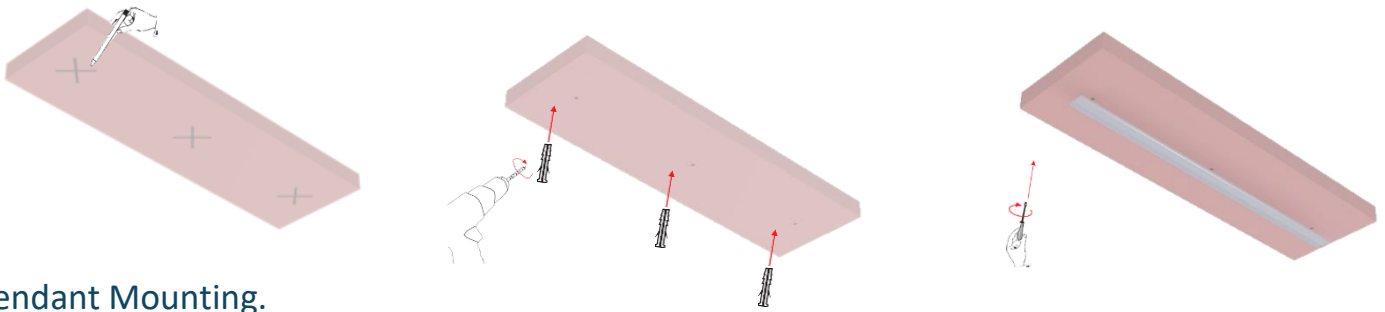

Pendant Mounting.

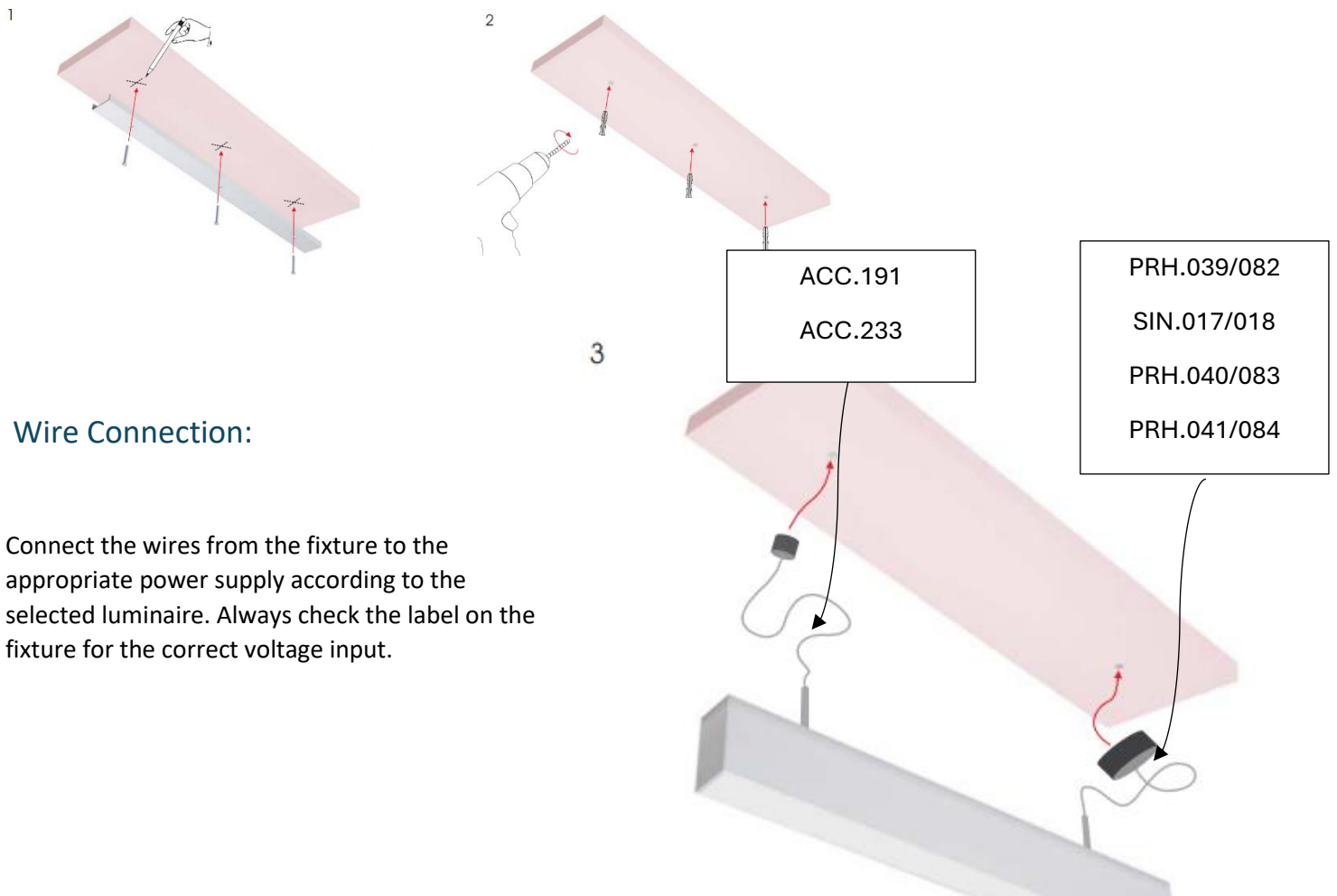

Wire Connection:

Connect the wires from the fixture to the appropriate power supply according to the selected luminaire. Always check the label on the fixture for the correct voltage input.

Recessed Installation.

1

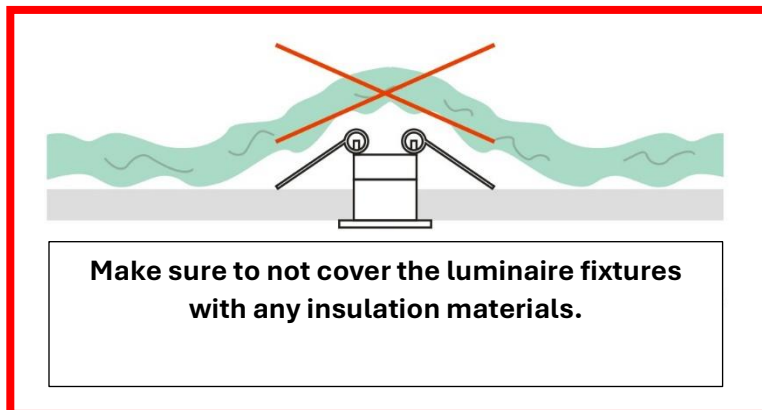
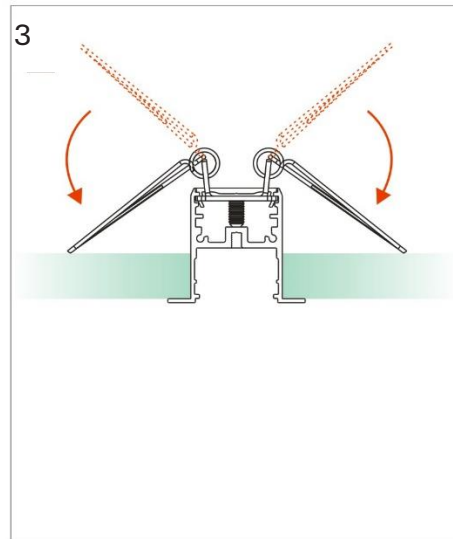
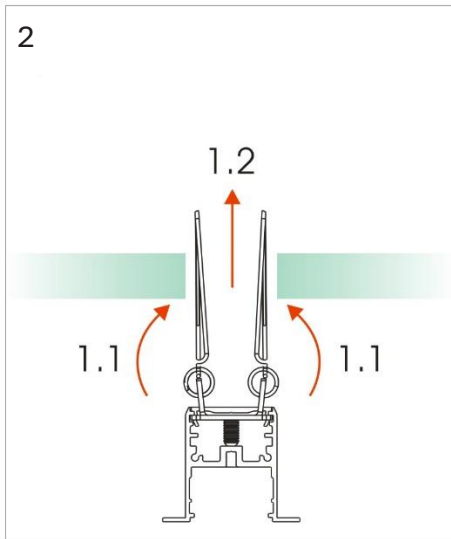
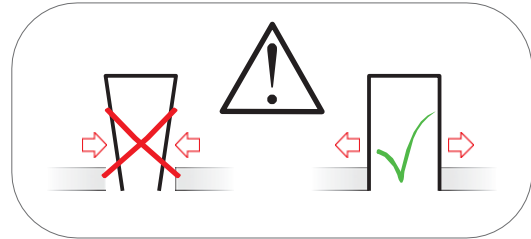
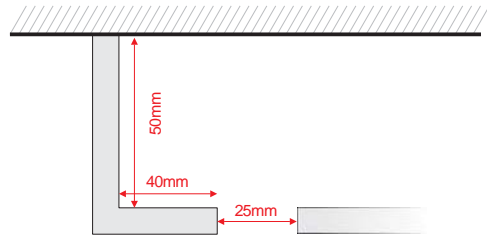
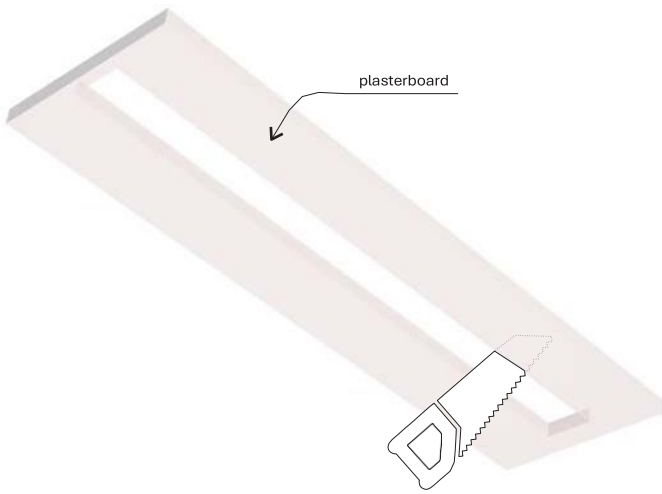

Cables and power connector's description.

From the power supply to the modules. A cable with a minimum cross section of **0,75mm²** must be used.

- All Link Modules (Directional/ Diffused/ Spot) are 24V PWM Dimmable.
 - In Tunable white models the positive pole is common for all channels. Thus, the controller or power supply that is going to be used for these models **must be Common Anode**.
 - Dimming can be done by PWM (Pulse Width Modulation) from 100Hz up to 4kHz.
 - For Directional Modules, the maximum length that can be achieved with a single power supply is 224cm.
 - For Diffused Modules, the maximum length that can be achieved with a single power supply is 497cm.
-
- From the power supply to the modules. A cable with a minimum cross section of **0,75mm²** must be used.
-
- During the installation of Link should not be supplied with voltage.

Technical specifications.

Length.	28cm/ module.	
LEDs.	Diffused & Directional Modules: Samsung LED, Spot Modules: CREE LEDS.	
LED quantity.	14leds/28cm (for directional models). 100leds/100cm (for diffused models)	
Lenses.	Directional: LEDIL DAISY MINI	
Beam angle.	Directional Modules: Monochromatic: 30°,55°,65° Tunable white(2in1): 60°	Spot Modules: Monochromatic: 25°,35°,50°
Dimming.	PWM 24VDC LINK MINI, MINI RC & MIDI / DALI, 1-10, CASAMBI LINK HV	
PWM Range.	0.1kHz – 4kHz.	
Ambient temperature.	-25°C / +50°C.	
Main body.	Powder coated, natural anodized anticorodal aluminum EN AW-6060.	
Power consumption. (±4%)	Diffused models: 5.6W/28cm Directional models: 7.2W/28cm Spot models: 6W/spot	